

User manual and installation instruction Control for Fire Ventilation RV 24-5

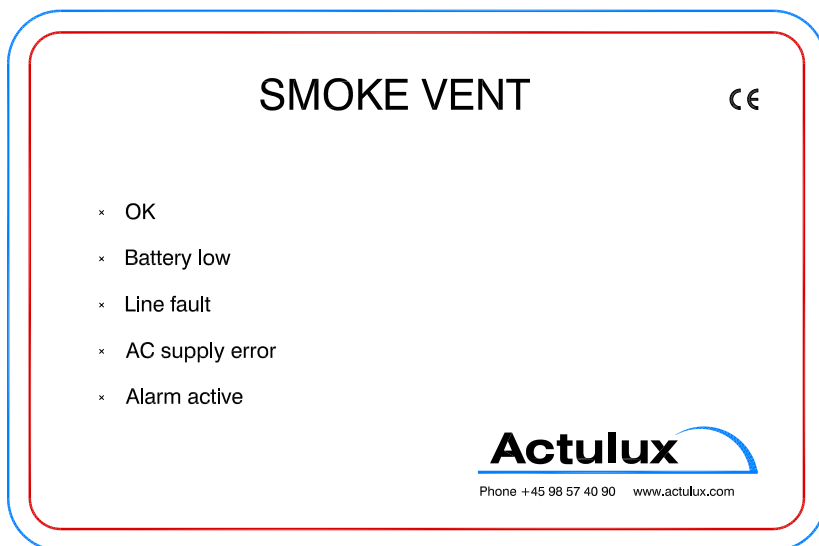

Fire ventilation

Comfort ventilation

24VDC max. 5A

1 Actuator output

1 Fire ventilation group, 1 comfort group

Connection for fire switch, wind and rain sensor, comfort switches, smoke detectors

#800285

Table of contents

Description.....	4
Safety	4
Installation.....	5
Maintenance and control.....	6
Installation diagramme.....	8-9
Serial connection of controls	10
Error indications on front panel	11
Error indications on board	11
Settings (DIP switches).....	11
Kabel sizes	12
Reset of smoke- and heat detectors.....	12
Kabel sizes - diagram.....	13
Technical specifications	16

Rev. 2 21-04-09 SW 080912 or newer

Manufacturer:

Actulux A/S
 Haandvaerkervej 2
 DK 9560 Hadsund
 DENMARK

Tel.: +45 98 57 40 90
 Fax: +45 96 15 28 00
 e-mail: info@actulux.com
www.actulux.com

Description of RV 24-5

The control for fire and comfort ventilation type RV 24-5 is designed to control the operation of opening systems for fire and comfort ventilation with 24 VDC electrical opening units.

RV 24-5 has inputs that can be activated by smoke detectors, fire switches (break the glass and press) and control switches for opening and closing for comfort ventilation. RV 24-5 also has inputs from weather sensors that can take care of closing the comfort ventilation in cases of rain or strong wind.

In order to make sure that the smoke ventilation in the building also works in an emergency case the RV 24-5 is equipped with 72 hours battery back-up. This battery makes sure that the smoke ventilation hatches can still be opened with full load in case of external supply failure. If the AC supply fails, the comfort switch does not work, however open windows can be closed with the reset button (inside the control).

Safety rules during installation and operation

RV 24-5 must only be installed and maintained by personnel authorized for installation of automatic electrical fire ventilation equipment.

Explosion danger

The back-up batteries contain large amounts of energy which can be released as explosion in connection with wrong handling. The following safety rules must therefore always be observed:

Never short-circuit a back-up battery.

Do not use external chargers on installed batteries.

Do not drop back-up batteries as strong acids can be released if they are broken.

If unauthorized chargers are used explosive gasses can be released from the battery.

Installation

RV 24-5 must be installed on a stable wall.

All cables are connected according to drawing page 8 - 9 and cable sizes page 12 - 13. Keep in mind that the operating voltage is 24V and that the max. voltage drop is 15% (3.6V). Please be sure to use correct cable cross section. In order to keep the demands on the CE marking of the system, the control must be supplied with an individual group with its own ground fault circuit interrupter. At the same time a repair interrupter must be mounted on the motor lines.

Important during connection

1. The actuators must always be connected through an overload interrupter, e.g. the Actulux LIP to limit the current. On controls with jumper setting (board A026V2 or higher, see left side) the cables can be connected in parallel or a combination of series and parallel. The jumper next to the output and fuse on the control must be set according to the number of opening systems with LIP connected to the actuator output. Please see diagram on the middle pages of the manual.

It is important to keep polarity of cables as shown in the diagram. The LED in the LIP must be on during opening sequence or the window may not be able to operate with snowload or the actuator gear may be damaged.

2. The circuit with manual fire switches must be closed with a 27k Ω resistance in the last switch. If more fire switches are installed, the cables must be run in series from switch to switch. If more smoke- and heat detectors are installed, cables must be run in series from detector to detector. Only by using smoke- and heat detectors supplied by Actulux, a correct line surveillance can be guaranteed.
3. The total operating current must not exceed 5A.
4. **NB: When the control is put into operation, the batteries must be connected first, after that the mains supply. Take care of the polarity, a wrong connection will destroy the control immediately.**

5 After connection the control must charge the batteries at least 12 hours before testing of functions and the system.

Accessories

- Waterproof fire switch IP67 No. 111720
- Board with 2 extra relay outputs 30V 0,5A No. 111655

Power consumption and overload interrupter

The max. current consumption of the Actulux actuators is limited by the electronic overload interrupter, type LIP. When selecting cables sizes the max. current consumption for each window must be taken into account.

- Consumption: Standard SA Power Single 4A each system (or see type label).
- SA Power Double 8A each system.
- Rotary 100 2,5A each system.
- RA 160 and RA Light 2,5A each system.

Important: Remember to install the electronic overload interrupter type LIP in series with each actuator.

When connecting external equipment to 24VDC terminals 12+13 the backup capacity of the batteries must be taken into consideration - ask your dealer.

Maintenance and control

The function of the control must be tested by authorized personnel at least once a year.

The maintenance includes:

Check that all actuator move to full opening when fire function (switch) is activated. **Should not be carried out if the wind is more than 6 m/sec.**

Control of the capacity of the batteries.

If the batteries are replaced it is important to use the same type as the batteries are carefully chosen to be able to deliver a large current (5 amp.) for a shorter time. Furthermore, the charging system is adjusted to the batteries. Other batteries may be designed for other operation situations, e.g. with less discharge current during a longer period.

Actulux A/S can always deliver original batteries.
The batteries must be exchanged every third (3) year!

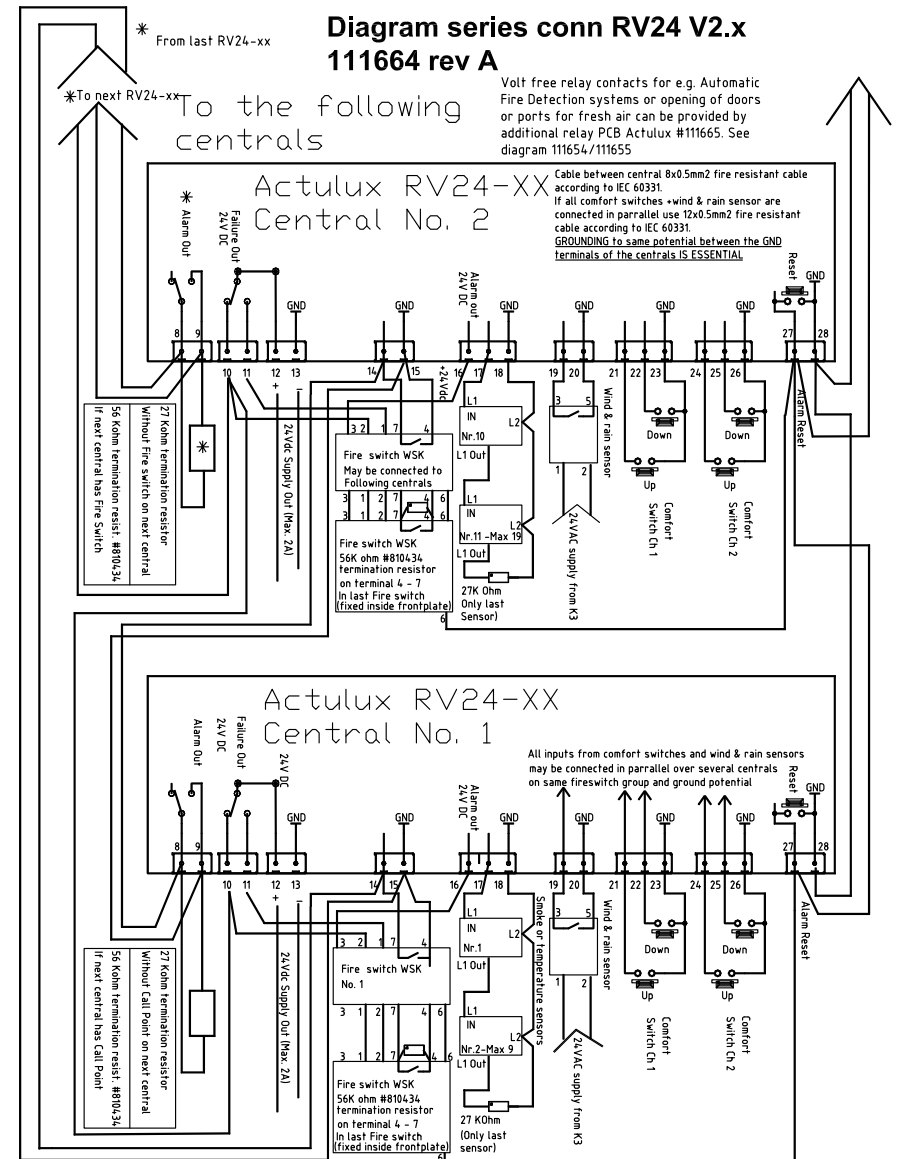

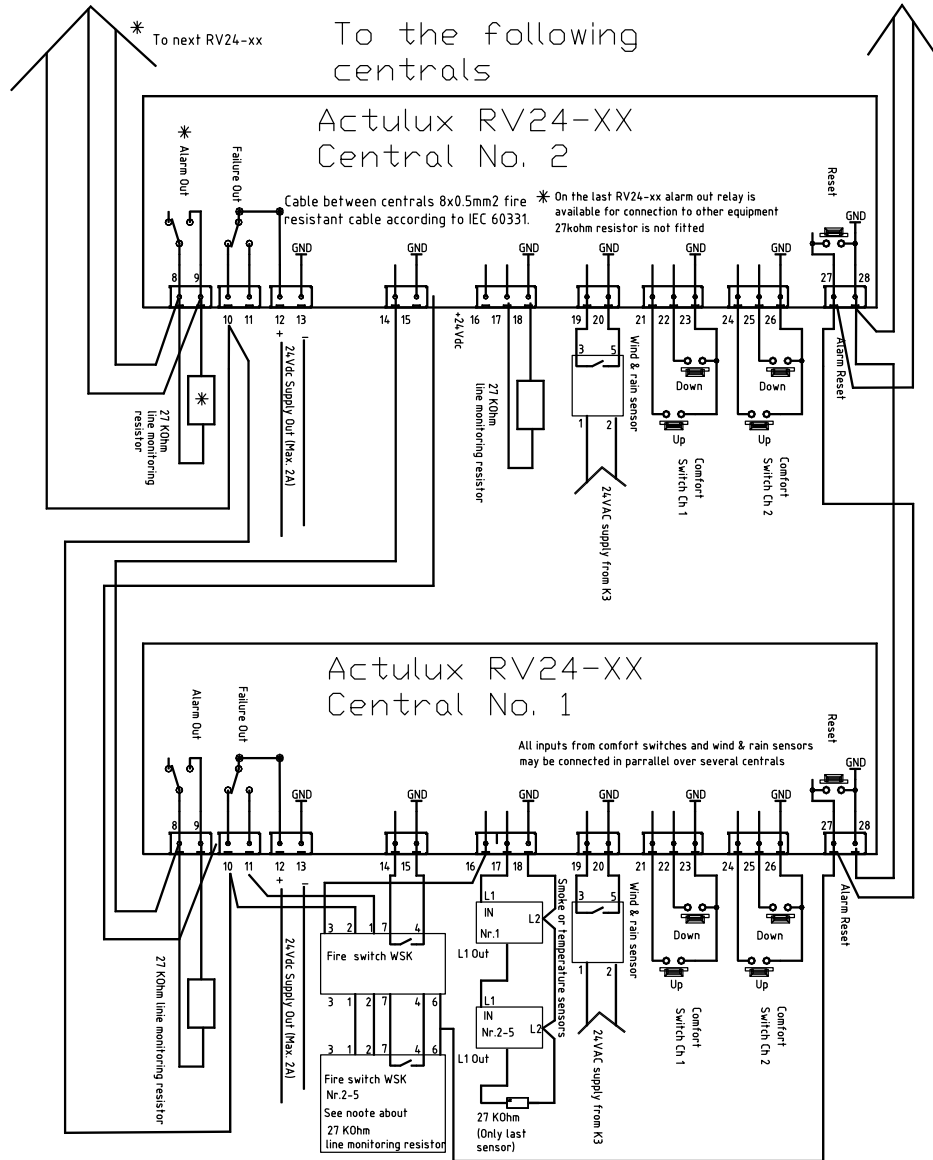

Serial connection, more controls only with heat- and smoke detectors and fire switch on control 1 (Master).

External light diodes on the front panel (light diode board)

OK	Green	lights if OK, otherwise switched off	LD12
Battery status	Yellow	flashes by error	LD13
Monitoring	Yellow	flashes by error	LD14
AC supply	Yellow	flashes by error	LD15
Alarm	Red	flashes by error	LD16

Internal light diodes on the control board

LD1	Red	Actuator output 1 opening
LD2	Green	Actuator output 1 closing
LD3	Red	Actuator output 2 opening
LD4	Green	Actuator output 2 closing
LD5	Red	Weather sensor active
LD6	Red	Line error actuator 1
LD7	Red	Line error actuator 2
LD8	Red	Line error fire switch
LD9	Red	Line error smoke detector
LD10		unused
LD11		unused

Jumper settings

	Std.	Function mounted	Function without jumper
S1	+	Buzzer	Buzzer interrupted
S2	+	Comfort switch impuls function	Comfort hold function
S3	-	Common comfort group	Two separate comfort groups
S4	+	Weekly closing pulse disconnected	Each week both actuator channels are opened and closed approx. 2 cm in order to secure the tightening of packings in the window
S5	-	Fire switch cable and surveillance of open and short circuit	Fire switch cable surveillance
S6	-	Failsafe-opens on all errors class B	Normal function class A

Cable sizes

It is very important to use the correct cable types and sizes to make sure that the fire ventilation system meets the standards and works correct in an emergency. The most important factors are the ability of the cables to resist heat and to make sure that the voltage drop in the cables to the actuators do not exceed 3.6VDC at full load on the fire ventilation hatches.

Fire resistant cables according to IEC 60331 must be used for the following functions:

Opening systems/actuators 24V	2 wires, see diagramme
Fire switch 24V	Min. 6 x 0,5 mm ²
Smoke detector 24V	Min. 2 x 0,5 mm ²
Heat detector	Min. 2 x 0,5 mm ²
Cable between controls	8 x 0,5 mm ²

Normal cables can be used for the following functions:

Supply for control 230VAC	e.g. 3 x 1,5PVIK-J
Comfort ventilation button 24V	Min. 3 x 0,5 mm ²
Wind- and rain sensor 24V	Min. 4 x 0,5 mm ²

Connection of more fire switches and smoke detectors

If more fire switches or smoke detectors are going to be connected to the RV 24-5 control the following cable routing must be observed: The cables are run from fire switch to fire switch so the cables are connected in series to make sure that the cable monitoring works correctly. Jumper J1 in fire switch is installed in the last fire switch in the chain in order to activate 27Kohm cable monitoring resistor. The cables must not all be lead to the control and installed in series in the control. The same applies when using more smoke / heat detectors.

Reset of smoke- and heat detector

After a smoke alarm the detector must be reset by dismantling the red +wire from the battery and cut off the 230V supply, e.g. by dismantling the fuse or disconnect the smoke- or heat detector from the base.

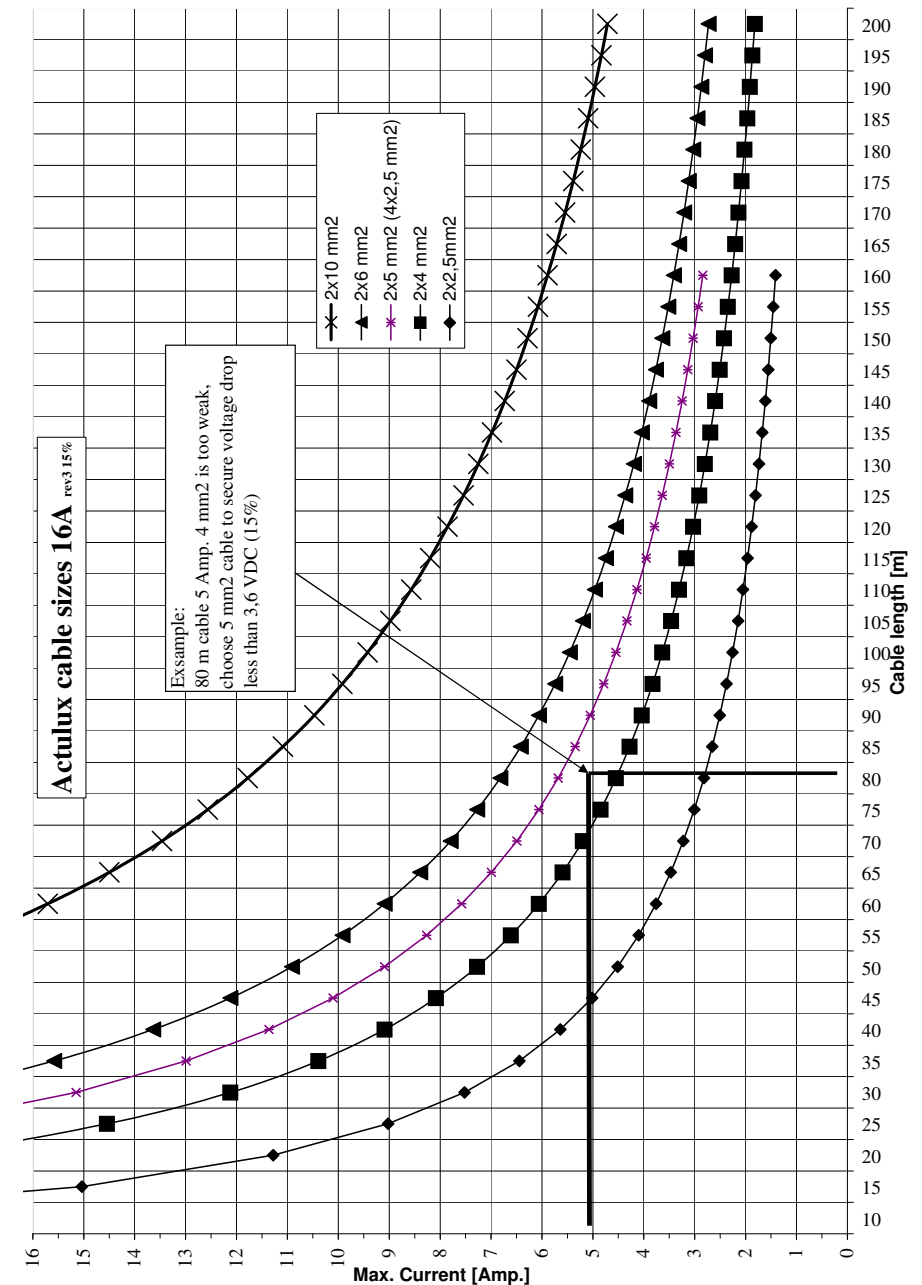



**DECLARATION OF CONFORMITY (UK)
KONFORMITÄTSEKTLÄRUNG (G)
OVERENSSTEMMELSESEKTLÆRING (DK)
CERTIFICAT DE CONFORMITE (F)
ATTESTAZIONE DI CONFORMITÀ (IT)**

We, **Actulux A/S
Haandværkervej 2
9560 Hadsund
Denmark**

declare under our sole responsibility that the product:
erklären in alleiniger Verantwortung, dass das Produkt:
erklærer under eget ansvar, at produktet:
certifions, sous notre propre responsabilité, que le produit :
dichiara sotto la propria responsabilità che il seguente prodotto:

RV 24-5, RV 24-24, RV 24-32

(name, type or model, lot, batch or serial number, possible sources and numbers of items)
(Bezeichnung, Typ oder Modell, Los-, Chargen- oder Seriennummer, möglichst Herkunft und Stückzahl)
(navn, type eller model, mængde, parti eller serienummer, mulig oprindelse og stykantal)
(nom, type ou modèle, lot ou numéro de série, origine et quantité)
(nome, tipo o modello, lotto, serie o numero di serie, sorgenti possibili e numeri di articoli)

to which this declaration relates is in conformity with the following standard(s) or other normative document(s).
auf das sich diese Erklärung bezieht, mit der/den folgenden Norm(en) oder normativen Dokument(en).
übereinstimmt.

til hvilket denne erklæring henfører, er i overensstemmelse med de følgende standard(er) eller andre normgivende dokument(er).
référént à ce certificat est conforme au(x) standard(s) ou autre(s) document(s) normatif(s).
è conforme alle disposizioni e normative sotto indicati.

**EN12101-10:2006
EN61000-6-2:2005 EN61000-6-4:2001
EN61000-3-2:2005 EN61000-3-3:1995**

(Title and/or number and date of issue of the standard(s) or other normative document(s))
(Titel und/oder Nummer sowie Ausgabedatum der Norm(en) oder der anderen normativen Dokumente)
(Titel og/eller nummer samt udgivelsesdato for standard(er) eller andre normgivende dokument(er))
(Titre et/ou numéro ainsi que date de publication de(s) standard(s) ou autre(s) document(s) normatif(s))
(Titolo ed/o numero e data d'emissione dello standard o dell' altro documento/documenti normativi)

following the provisions of Directive 73/23/EEC - 89/336/EEC and 93/68/EEC.
gemäss den Bestimmungen der Richtlinie 73/23/EEC - 89/336/EEC und 93/68/EEC.
i henhold til direktivets bestemmelser 73/23/EEC - 89/336/EEC og 93/68/EEC.
selon les stipulations des directives 73/23/EEC - 89/336/EEC et 93/68/EEC.
ed alle direttive 73/23/EEC - 89/336/EEC ed 93/68/EEC.

Hadsund 7. november 2007
(Place and date of issue)
(Ort und Datum der Ausstellung)
(Sted og dato for udstedelse)
(Posto e data d'emissione)
(Lieu et date d'émission)

Jens Buus
(Name and signature or equivalent marking of authorized person)
(Name und Unterschrift oder gleichwertige Kennzeichnung des Befugten)
(Navn og underskrift eller ækvivalent mærkning af autoriseret person)
(Nome e firma o marcatura equivalente della persona autorizzata)
(Nom et signature ou apposition équivalente d'une personne autorisée)

2 channel LIP connection

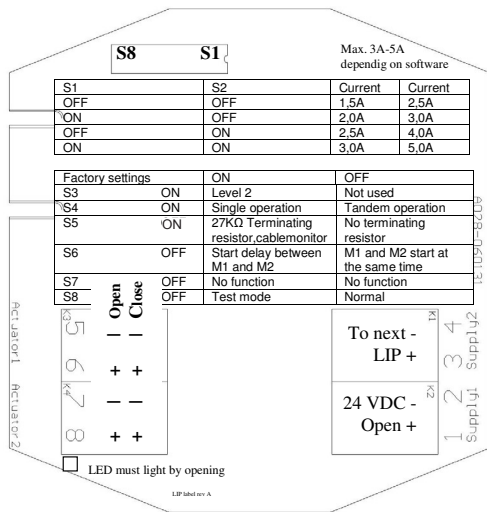

Fire switch connection

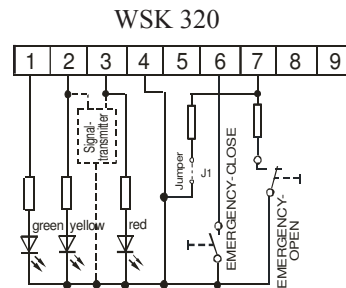

- 1 green LED OK (closing)
 - 2 yellow LED (flashes on error)
 - 3 red LED alarm (emergency opening)
 - 4 ground (-)
 - 5 not used
 - 6 fire switch reset
 - 7 fire switch emergency opening
- Jumper J1 must only be set in the last or only fire switch

Current Limiter Type LIP

The current limiter type LIP is used as current limiter between 24VDC supply and 1 or 2 actuator(s). When the adjusted current limit is reached, the speed of the actuators is reduced. When max. power on the actuator is exceeded, the actuator stops.

1 channel LIP connection

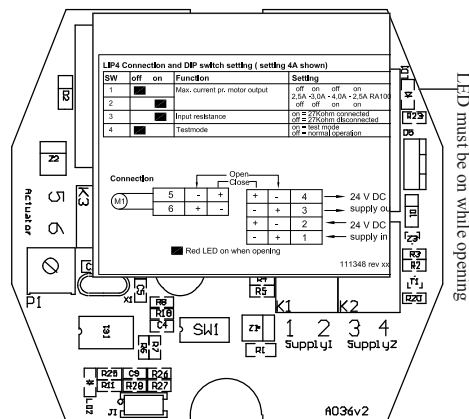

Technical specifications RV 24-5:

Power supply	: 230VAC - max. 80VA
Operating temperature	: -5°C - +40°C
Density	: IP65
Colour	: RAL 7035
Dimensions WxHxD	: 296x260x132
Weight incl. batteries	: 8 kgs
Battery capacity	: 24V (2x12V) 7,2 AH
Max. total load	: 24V DC 5A
Max. load each motor line	: 24V DC 5A
Motor lines	: 1 pc. (terminals 16mm ²)
Fire switch groups	: 1 group, max. 10 external fire switches
Comfort ventilation	: 1 group, unlimited amount of switches
Smoke- and heat detector	: Max. 9 pcs.
Wind- and rain sensor	: Input for closing of window
Serial connection af controls	: Possible

Manufacturer:

Actulux A/S

Haandvaerkervej 2

DK 9560 Hadsund

DENMARK

Tel.: +45 98 57 40 90

Fax: +45 96 15 28 00

e-mail: info@actulux.com

www.actulux.com